

SG392, SG394, SG396

Технические характеристики

По вопросам продаж и поддержки обращайтесь:

Алматы (7273)495-231	Казань (843)206-01-48	Новокузнецк (3843)20-46-81	Смоленск (4812)29-41-54
Архангельск (8182)63-90-72	Калининград (4012)72-03-81	Новосибирск (383)227-86-73	Сочи (862)225-72-31
Астрахань (8512)99-46-04	Калуга (4842)92-23-67	Омск (3812)21-46-40	Ставрополь (8652)20-65-13
Барнаул (3852)73-04-60	Кемерово (3842)65-04-62	Орел (4862)44-53-42	Сургут (3462)77-98-35
Белгород (4722)40-23-64	Киров (8332)68-02-04	Оренбург (3532)37-68-04	Тверь (4822)63-31-35
Брянск (4832)59-03-52	Краснодар (861)203-40-90	Пенза (8412)22-31-16	Томск (3822)98-41-53
Владивосток (423)249-28-31	Красноярск (391)204-63-61	Пермь (342)205-81-47	Тула (4872)74-02-29
Волгоград (844)278-03-48	Курск (4712)77-13-04	Ростов-на-Дону (863)308-18-15	Тюмень (3452)66-21-18
Вологда (8172)26-41-59	Липецк (4742)52-20-81	Рязань (4912)46-61-64	Ульяновск (8422)24-23-59
Воронеж (473)204-51-73	Магнитогорск (3519)55-03-13	Самара (846)206-03-16	Уфа (347)229-48-12
Екатеринбург (343)384-55-89	Москва (495)268-04-70	Санкт-Петербург (812)309-46-40	Хабаровск (4212)92-98-04
Иваново (4932)77-34-06	Мурманск (8152)59-64-93	Саратов (845)249-38-78	Челябинск (351)202-03-61
Ижевск (3412)26-03-58	Набережные Челны (8552)20-53-41	Севастополь (8692)22-31-93	Череповец (8202)49-02-64
Иркутск (395)279-98-46	Нижний Новгород (831)429-08-12	Симферополь (3652)67-13-56	Ярославль (4852)69-52-93
Россия (495)268-04-70	Киргизия (996)312-96-26-47	Казахстан (7172)727-132	

Vector Signal Generators

SG390 Series — DC to 2 GHz, 4 GHz and 6 GHz vector signal generators



SG390 Series Vector Signal Generators

- DC to 2 GHz, 4 GHz or 6 GHz
- Dual baseband arb generators
- Vector and analog modulation
- I/Q modulation inputs (300 MHz RF BW)
- ASK, FSK, MSK, PSK, QAM, VSB, and custom I/Q
- Presets for GSM, EDGE, W-CDMA, APCO-25, DECT, NADC, PDC, ATSC-DTV & TETRA
- GPIB, RS-232 & Ethernet interfaces

Introducing the new SG390 Series Vector Signal Generators — high performance, affordable RF sources.

Three new RF Signal Generators, with carrier frequencies from DC to 2.025 GHz, 4.050 GHz and 6.075 GHz, support both analog and vector modulation. The instruments utilize a new RF synthesis technique which provides spur free outputs with low phase noise (-116 dBc/Hz at 1 GHz) and extraordinary frequency resolution (1 μ Hz at any frequency). Both analog modulation and vector baseband generators are included as standard features.

The instruments use an ovenized SC-cut oscillator as the standard timebase, providing a 100 fold improvement in the stability (and a 100 fold reduction in the in-close phase noise) compared to instruments which use a TCXO timebase.

A New Frequency Synthesis Technique

The SG390 Series Signal Generators are based on a new frequency synthesis technique called Rational Approximation Frequency Synthesis (RAFS). RAFS uses small integer divisors in a conventional phase-locked loop (PLL) to synthesize a frequency that would be close to the desired frequency (typically within ± 100 ppm) using the nominal PLL reference frequency. The PLL reference frequency, which is sourced by a voltage controlled crystal oscillator that is phase locked to a dithered direct digital synthesizer, is adjusted so that the PLL generates the exact frequency. Doing so provides a high phase comparison frequency (typically 25 MHz)

yielding low phase noise while moving the PLL reference spurs far from the carrier where they can be easily removed. The end result is an agile RF source with low phase noise, essentially infinite frequency resolution, without the spurs of fractional-N synthesis or the cost of a YIG oscillator.

Analog Modulation

The SG390 Signal Generators offer a wide variety of modulation capabilities. Modes include amplitude modulation (AM), frequency modulation (FM), phase modulation (Φ M), and pulse modulation. There is an internal modulation source as well as an external modulation input. The internal modulation source produces sine, ramp, saw, square, and noise waveforms. An external modulation signal may be applied to the rear-panel modulation input. The internal modulation generator is available as an output on the rear panel.

Unlike traditional analog signal generators, the SG390 Series can sweep continuously from DC to 62.5 MHz. And for frequencies above 62.5 MHz, each sweep range covers more than an octave.

Vector Modulation

The SG390 series builds upon this performance by adding full support for vector signal modulation on RF carriers between 400 MHz and 6.075 GHz. It features a dual, arbitrary waveform generator operating at 125 MHz for baseband signal generation. The generator has built-in support for the most common vector modulation schemes: ASK, QPSK, DQPSK, $\pi/4$ DQPSK, 8PSK, FSK, CPM. QAM (4 to 256), 8VSB, and 16VSB. It also includes built-in support for all the standard pulse shaping filters used in digital communications: raised cosine, root-raised cosine, Gaussian, rectangular, triangular, and more. Lastly, it provides direct support for the controlled injection of additive white Gaussian noise (AWGN) into the signal path.

Internal baseband generators

Using a novel architecture for I/Q modulation, the SG390 series provides quick, user-friendly waveform generation. The baseband generator supports the playback of pure digital data. It automatically maps digital symbols into a selected I/Q constellation at symbol rates of up to 6 MHz and passes the result through the selected pulse shaping filter to generate a final waveform updated in real time at 125 MHz. This baseband signal is then modulated onto an RF carrier using standard I/Q modulation techniques.

Preset communications protocols (GSM, GSM EDGE, W-CDMA, APCO-25, DECT, NADC, PDC, TETRA, and ATSC DTV) quickly configure the signal generator to the correct modulation type, symbol data rates, TDMA duty cycles and digital waveform filters. The preset protocols also configure the rear-panel TDMA, START of FRAME, and SYMBOL CLOCK digital outputs. The baseband generators can be configured for these protocols without the use of external computers or third party software.

The I/Q waveforms are computed in real time. Symbols are mapped to constellations, digitally filtered, and up-sampled to 125 Msps to drive the I/Q modulator via dual 14-bit DACs. The symbols can be a fixed pattern, PRBS data from an internal source, or come from a downloaded user list of up to 16 Mbits. The constellation mapping can be modified by the user. Digital filters include Nyquist, root Nyquist, Gaussian, rectangular, linear, sinc, and user-defined FIR .

External I/Q Modulation

The rear-panel BNC I/Q modulation inputs and outputs enable arbitrary vector modulation via an external source. The external signal path supports more than 300 MHz of bandwidth with a full scale range of ± 0.5 V and a 50 Ω input impedance.

Baseband Dual Arbitrary Waveform Generator for IQ Modulation

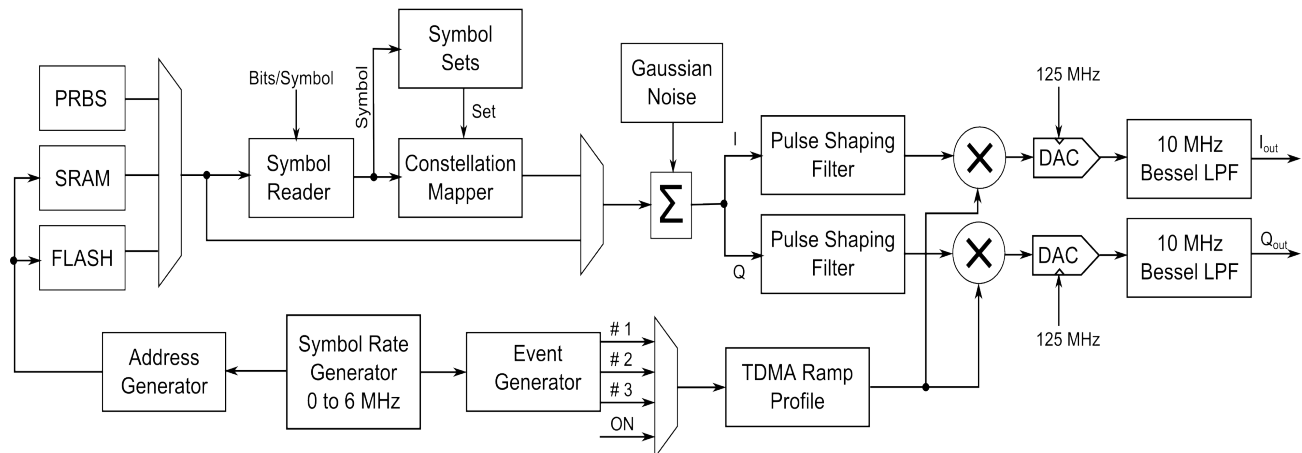

SG390 Series Vector Signal Generators

Power vs Frequency

All SRS RF signal generators have cascaded stages of amplifiers and digital attenuators to drive the RF output. Five stages can provide up to +25 dB of gain to -130 dB of attenuation in 156 digitally controlled steps. During factory calibration the output power is measured at 32 frequencies per octave for each of the 156 attenuator steps to populate a memory matrix with about 40,000 elements. When set to a particular frequency and power, the instrument interpolates between these matrix elements to determine the best attenuator setting. An analog attenuator is used to provide 0.01 dB resolution between matrix elements and to compensate for residual thermal effects.

This method eliminates the need for precision attenuators and automatic level controls (ALC) without any sacrifice in performance. Eliminating the ALC also removes its unwanted interactions with amplitude, pulse and I/Q modulation.

OCXO or Rubidium Timebase

The SG390 Series come with a oven-controlled crystal oscillator (OCXO) timebase. The timebase uses a third-overtone stress-compensated 10 MHz resonator in a thermostatically controlled oven. The timebase provides very low phase noise and very low aging. An optional rubidium oscillator (Opt. 04) may be ordered to substantially reduce frequency aging and improve temperature stability. An external 10 MHz timebase reference may be supplied to the rear-panel timebase input.

Easy Communication

Remote operation is supported with GPIB, RS-232 and Ethernet interfaces. All instrument functions can be controlled and read over any of the interfaces. Up to nine instrument configurations can be saved in non-volatile memory.

Ordering Information

SG392	2 GHz signal generator
SG394	4 GHz signal generator
SG396	6 GHz signal generator
Option 04	Rubidium timebase
RM2U-S	Single rack mount kit
RM2U-D	Dual rack mount kit

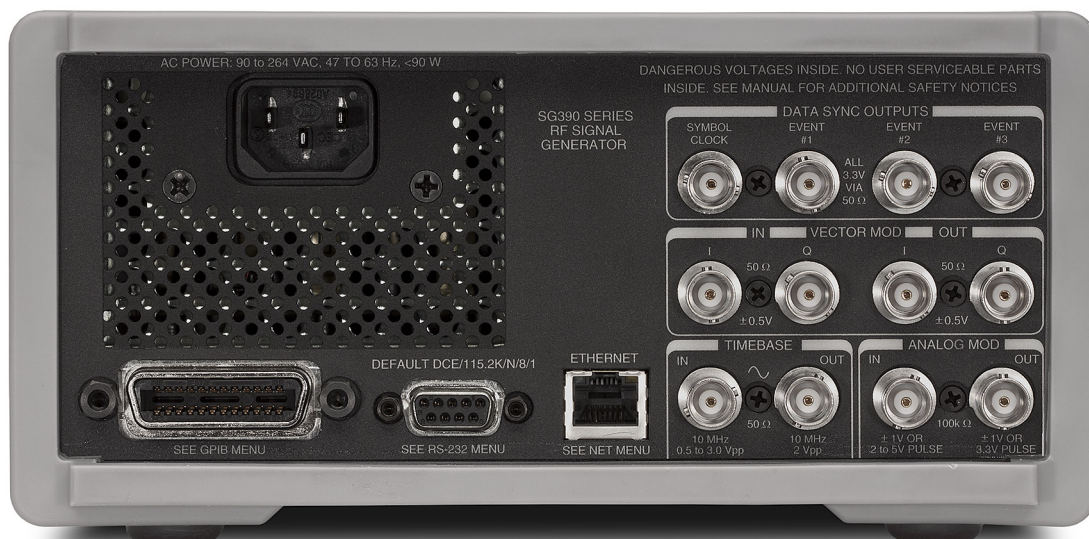

SG394 rear panel

Frequency Setting

Frequency ranges	DC to 62.5 MHz (BNC output, all models)
SG392	950 kHz to 2.025 GHz (N-type output)
SG394	950 kHz to 4.05 GHz (N-type output)
SG396	950 kHz to 6.075 GHz (N-type output)
Frequency resolution	1 μ Hz at any frequency
Switching speed	<8 ms (to within 1 ppm)
Frequency error	$<(10^{-18} + \text{timebase error}) \times f_C$
Frequency stability	1×10^{-11} (1 s Allan variance)

Front-Panel BNC Output

Frequency range	DC to 62.5 MHz
Amplitude	1.00 Vrms to 0.001 Vrms
Offset	± 1.5 VDC
Offset resolution	5 mV
Max. excursion	1.817 V (amplitude + offset)
Amplitude resolution	<1 %
Amplitude accuracy	± 5 %
Harmonics	<-40 dBc
Spurious	<-75 dBc
Output coupling	DC, 50 Ω ± 2 %
User load	50 Ω
Reverse protection	± 5 VDC

Front-Panel N-Type Output

Frequency range	
SG392	950 kHz to 2.025 GHz
SG394	950 kHz to 4.050 GHz
SG396	950 kHz to 6.075 GHz
Power output	
SG392	+16.5 dBm to -110 dBm
SG394	+16.5 dBm to -110 dBm (<3 GHz)
SG396	+16.5 dBm to -110 dBm (<4 GHz)
Voltage output	
SG392	1.5 Vrms to 0.7 μ Vrms
SG394	1.5 Vrms to 0.7 μ Vrms (<3 GHz)
SG396	1.5 Vrms to 0.7 μ Vrms (<4 GHz)
Power resolution	0.01 dBm
Power accuracy	± 1 dB
Output coupling	AC, 50 Ω
User load	50 Ω
VSWR	<1.6
Reverse protection	30 VDC, +25 dBm RF

Spectral Purity of the RF Output Referenced to 1 GHz*

Sub harmonics	None
Harmonics	<-25 dBc (<+7 dBm, N-type output)
Spurious	
<10 kHz offset	<-65 dBc
>10 kHz offset	<-75 dBc
Phase noise (typ.)	
10 Hz offset	-80 dBc/Hz
1 kHz offset	-102 dBc/Hz
20 kHz offset	-116 dBc/Hz (SG392 & SG394)
	-114 dBc/Hz (SG396)
1 MHz offset	-130 dBc/Hz (SG392 & SG394)
	-124 dBc/Hz (SG396)

Residual FM (typ.)	1 Hz rms (300 Hz to 3 kHz BW)
Residual AM (typ.)	0.006% rms (300 Hz to 3 kHz BW)

* Spurs, phase noise and residual FM scale by 6 dB/octave to other carrier frequencies

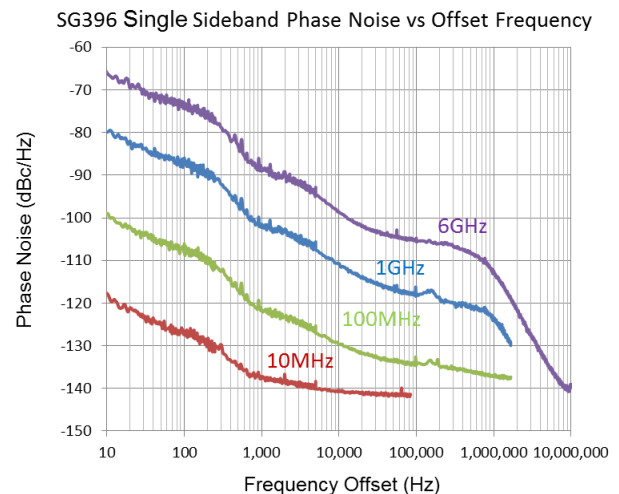
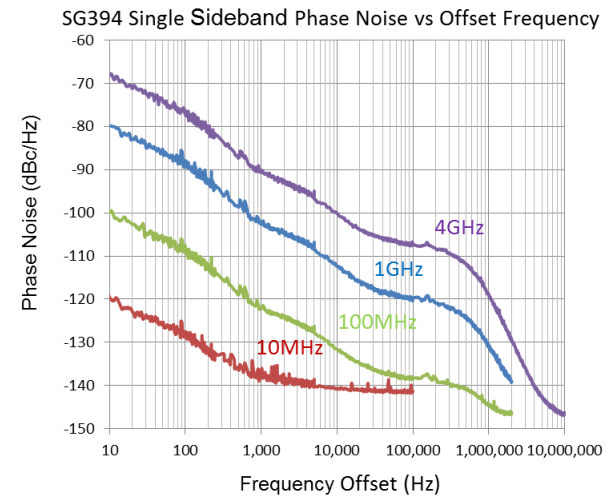

Phase Setting on Front-Panel Outputs

Max. phase step	$\pm 360^\circ$
Phase resolution	0.01 $^\circ$ (DC to 100 MHz)
	0.1 $^\circ$ (100 MHz to 1 GHz)
	1.0 $^\circ$ (1 GHz to 8.1 GHz)

Standard OCXO Timebase

Oscillator type	Oven controlled, 3 rd OT, SC-cut crystal
Stability (0 to 45 $^\circ$ C)	$\leq \pm 0.002$ ppm
Aging	$\leq \pm 0.05$ ppm/year

SG390 Series Specifications (Analog)

Rubidium Timebase (Opt. 04)

Oscillator type	Oven controlled, 3 rd OT, SC-cut crystal
Physics package	Rubidium vapor frequency discriminator
Stability (0 to 45°C)	<±0.0001 ppm
Aging	<±0.001 ppm/year

Timebase Input

Frequency	10 MHz, ±2 ppm
Amplitude	0.5 to 4 V _{pp} (-2 dBm to +16 dBm)
Input impedance	50 Ω, AC coupled

Timebase Output

Frequency	10 MHz, sine
Source	50 Ω, DC transformer coupled
Amplitude	1.75 V _{pp} ±10% (8.8 dBm ± 1 dBm)

Output Power Error

SG392 power error (-30 dBm to +10 dBm, DC to 2 GHz)

SG392 Output Power Error vs. Frequency

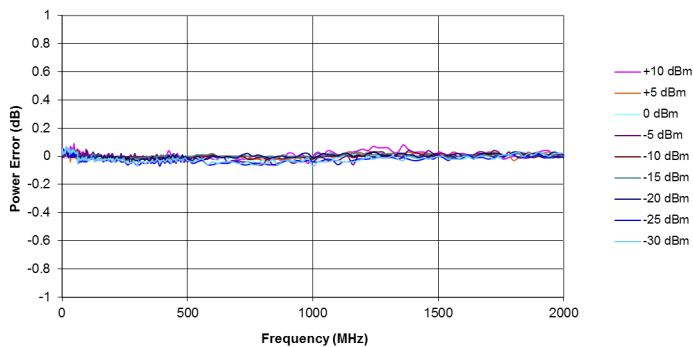

SG394 power error (-30 dBm to +10 dBm, DC to 4 GHz)

SG394 Output Power Error vs. Frequency

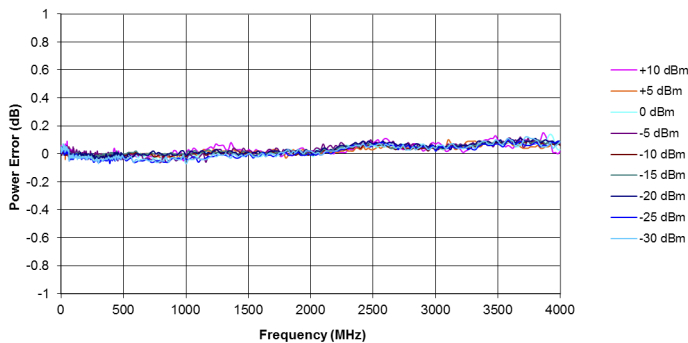

SG396 power error (-30 dBm to +10 dBm, DC to 6 GHz)

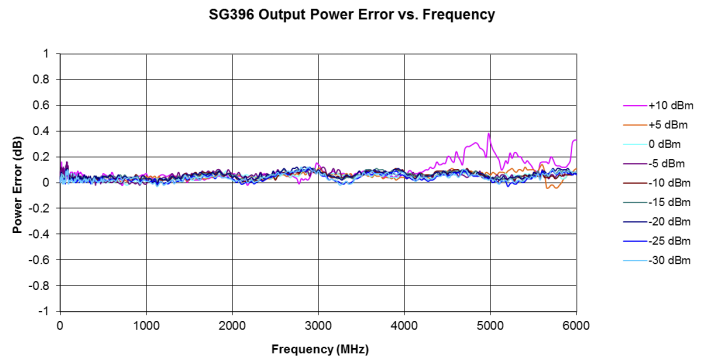

Internal Modulation Source

Waveforms	Sine, ramp, saw, square, pulse, noise
Sine THD	-80 dBc (typ. at 20 kHz)
Ramp linearity	<0.05% (1 kHz)
Rate	1 μHz to 500 kHz (f _c ≤ 62.5 MHz (SG392 & SG394)) (f _c ≤ 93.75 MHz (SG396))
	1 μHz to 50 kHz (f _c > 62.5 MHz (SG392 & SG394)) (f _c > 93.75 MHz (SG396))
Rate resolution	1 μHz
Rate error	1:2 ³¹ + timebase error
Noise function	White Gaussian noise (rms = dev / 5)
Noise bandwidth	1 μHz < ENBW < 50 kHz
Pulse generator period	1 μs to 10 s
Pulse generator width	100 ns to 9999.9999 ms
Pulse timing resolution	5 ns
Pulse noise function	PRBS 2 ⁵ - 2 ¹⁹ . Bit period (100 + 5N) ns

Modulation Waveform Output

Output impedance	50 Ω (for reverse termination)
User load	Unterminated 50 Ω coax
AM, FM, ΦM	±1 V for ± full deviation
Pulse/Blank	"Low" = 0 V, "High" = 3.3 VDC

External Modulation Input

Modes	AM, FM, ΦM, Pulse, Blank
Unmodulated level	0 V input for unmodulated carrier
AM, FM, ΦM	±1 V input for ± full deviation
Modulation bandwidth	>100 kHz
Modulation distortion	<-60 dB
Input impedance	100 kΩ
Input offset	<500 μV
Pulse/Blank threshold	+1 VDC

Amplitude Modulation

Range	0 to 100 % (decreases above +7 dBm)
Resolution	0.1 %
Modulation source	Internal or external
Modulation distortion	
BNC output	<1 % ($f_C < 62.5$ MHz, $f_M = 1$ kHz)
N-type output	<3 % ($f_C > 62.5$ MHz, $f_M = 1$ kHz)
Modulation bandwidth	>100 kHz

Frequency Modulation

Frequency deviation	
Minimum	0.1 Hz
Maximum (SG392 & SG394)	
$f_C \leq 62.5$ MHz	Smaller of f_C or 64 MHz - f_C
62.5 MHz < $f_C \leq 126.5625$ MHz	1 MHz
126.5625 MHz < $f_C \leq 253.125$ MHz	2 MHz
253.125 MHz < $f_C \leq 506.25$ MHz	4 MHz
506.25 MHz < $f_C \leq 1.0125$ GHz	8 MHz
1.0125 GHz < $f_C \leq 2.025$ GHz	16 MHz
2.025 GHz < $f_C \leq 4.050$ GHz (SG394)	32 MHz
Maximum (SG396)	
$f_C \leq 93.75$ MHz	Smaller of f_C or 96 MHz - f_C
93.75 MHz < $f_C \leq 189.84375$ MHz	1 MHz
189.84375 MHz < $f_C \leq 379.6875$ MHz	2 MHz
379.6875 MHz < $f_C \leq 759.375$ MHz	4 MHz
759.375 MHz < $f_C \leq 1.51875$ GHz	8 MHz
1.51875 GHz < $f_C \leq 3.0375$ GHz	16 MHz
3.0375 GHz < $f_C \leq 6.075$ GHz	32 MHz
Deviation resolution	0.1 Hz
Deviation accuracy	<0.1 %
	($f_C \leq 62.5$ MHz (SG392 & SG394))
	($f_C \leq 93.75$ MHz (SG396))
	<3 %
	($f_C > 62.5$ MHz (SG392 & SG394))
	($f_C > 93.75$ MHz (SG396))
Modulation source	Internal or external
Modulation distortion	<-60 dB ($f_C = 100$ MHz, $f_M = f_D = 1$ kHz)
Ext. FM carrier offset	<1:1,000 of deviation
Modulation bandwidth	500 kHz
	($f_C \leq 62.5$ MHz (SG392 & SG394))
	($f_C \leq 93.75$ MHz (SG396))
	100 kHz
	($f_C > 62.5$ MHz (SG392 & SG394))
	($f_C > 93.75$ MHz (SG396))

Frequency Sweeps (Phase Continuous)

Frequency span	10 Hz to entire sweep range
Sweep ranges	
SG392 & SG394	DC to 64 MHz
	59.375 MHz to 128.125 MHz
	118.75 MHz to 256.25 MHz
	237.5 MHz to 512.5 MHz
	475 MHz to 1025 MHz
	950 MHz to 2050 MHz
	1900 MHz to 4100 MHz (SG394)

SG396	DC to 96 MHz
	89.0625 MHz to 192.188 MHz
	178.125 MHz to 384.375 MHz
	356.25 MHz to 768.75 MHz
	712.5 MHz to 1537.5 MHz
	1425 MHz to 3075 MHz
	2850 MHz to 6150 MHz
Deviation resolution	0.1 Hz
Sweep source	Internal or external
Sweep distortion	<0.1 Hz + (deviation / 1,000)
Sweep offset	<1:1,000 of deviation
Sweep function	Triangle, ramp or sine up to 120 Hz

Phase Modulation

Deviation	0 to 360°
Deviation resolution	0.01° to 100 MHz, 0.1° to 1 GHz, 1° above 1 GHz
Deviation accuracy	<0.1 %
	($f_C \leq 62.5$ MHz (SG392 & SG394))
	($f_C \leq 93.75$ MHz (SG396))
	<3 %
	($f_C > 62.5$ MHz (SG392 & SG394))
	($f_C > 93.75$ MHz (SG396))
Modulation source	Internal or external
Modulation distortion	<-60 dB ($f_C = 100$ MHz, $f_M = 1$ kHz, $\Phi_D = 50^\circ$)
Modulation bandwidth	500 kHz
	($f_C > 62.5$ MHz (SG392 & SG394))
	($f_C > 93.75$ MHz (SG396))
	100 kHz
	($f_C > 62.5$ MHz (SG392 & SG394))
	($f_C > 93.75$ MHz (SG396))

Pulse/Blank Modulation

Pulse mode	Logic "High" turns RF "on"
Blank mode	Logic "High" turns RF "off"
On/Off ratio	
BNC output	70 dB
Type-N output	57 dB ($f_C \leq 1$ GHz)
	40 dB (1 GHz $\leq f_C < 4$ GHz)
	35 dB ($f_C \geq 4$ GHz)
Pulse feed-through	10 % of carrier for 20 ns at turn on (typ.)
Turn on/off delay	60 ns
RF rise/fall time	20 ns
Modulation source	Internal or external pulse

General

Ethernet (LAN)	10/100 Base-T.TCP/IP & DHCP default
GPIO	IEEE488.2
RS-232	4800 to 115,200 baud, RTS/CTS flow
Line power	<90 W, 90 to 264 VAC, 47 to 63 Hz (with PFC)
Dimensions, weight	8.5" x 3.5" x 13" (WHD)
Weight	10 lbs.
Warranty	One year parts and labor on defects in materials and workmanship

SG390 Series Specifications (Vector)

External I/Q Modulation

Carrier frequency range	400 MHz to 2.025 GHz (SG392) 400 MHz to 4.05 GHz (SG394) 400 MHz to 6.075 GHz (SG396)
I/Q inputs	50 Ω, ±0.5 V (rear panel)
I/Q full scale input	$(I^2 + Q^2)^{1/2} = 0.5 \text{ V}$
Modulation bandwidth	300 MHz RF bandwidth
I or Q input offset	<500 μV
Carrier suppression	>40 dBc (>35 dBc above 4 GHz)

External I/Q Bandwidth

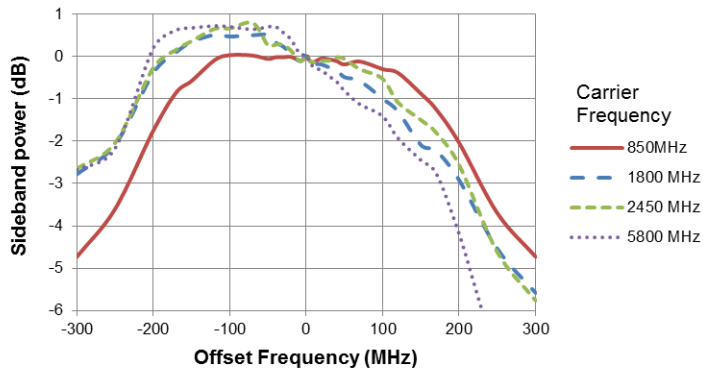

Dual Baseband Generator (for Vector I/Q Modulation)

Channels	2 (I and Q)
DAC data format	Dual 14-bit at 125 MS/s
Reconstruction filter	10 MHz, 3rd order Bessel LPF
Arb symbol memory	Up to 16 Mbits
Symbol rate	1 Hz to 6 MHz (1 μHz resolution)
Symbol length	1 to 9 bits (maps to constellation)
Symbol mapping	Default or user-defined constellation
Symbol source	User-defined symbols, built-in PRBS generator, or settable pattern generator
PRBS length	$2^n - 1$ ($5 < n < 32$) (31 to about 4.3×10^9 symbols)
Pattern Generator	16 bits
Digital Filtering	
Filter type	Nyquist, Root Nyquist, Gaussian, Rectangular, Linear, Sinc, User FIR
Filter length	24 symbols
Noise Impairments	
Additive noise Level	White, Gaussian -70 dBc to -10 dBc (band limited by digital filter)

Vector Modulation

Modulation type	PSK, QAM, FSK, CPM, MSK, ASK, VSB
PSK derivatives	PSK, BPSK, QPSK, OQPSK, DQPSK, $\pi/4$ DQPSK, 8 PSK, 16 PSK, $3\pi/8$ 8 PSK
QAM derivatives	4, 16, 32, 64, 256
FSK derivatives	1-bit to 4-bit with deviations from 0 to 6 MHz
ASK derivatives	1-bit to 4-bit
CMP derivatives	1-bit to 4-bit with modulation indices from 0 to 1.0
VSB derivatives	8 and 16 (at rates to 12 MS/s)
Preset modes	GSM, GSM-EDGE, W-CDMA, APCO-25, DECT, NADC, PDC, TETRA, ATSC DTV, and audio clip (analog AM and FM)

Rear-Panel Markers

Type	Symbol Clock, Data Frame, TDMA, and user-defined
Amplitude	0.5 to 4 Vpp (-2 dBm to +16 dBm)
Output impedance	50 Ω, AC coupled

EVM or FSK Errors

TETRA	<i>($\pi/4$ Diff Quad PSK, 24.3 kS/s, 420 MHz)</i>
EVM (typ.)	0.76 % (0 dBm)

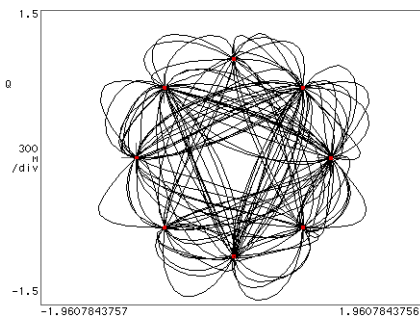

TETRA constellation (420 MHz carrier)

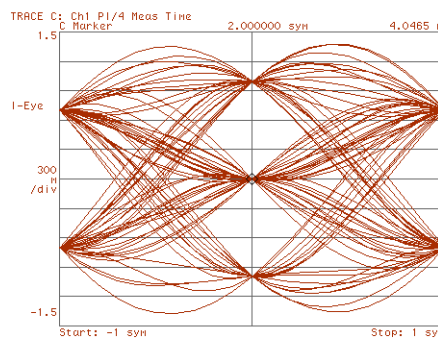

TETRA I-EYE diagram (420 MHz carrier)

NADC $(\pi/4$ Diff Quad PSK, 24.3 kS/s, 875 MHz)
 EVM (typ.) 0.33 % (0 dBm)

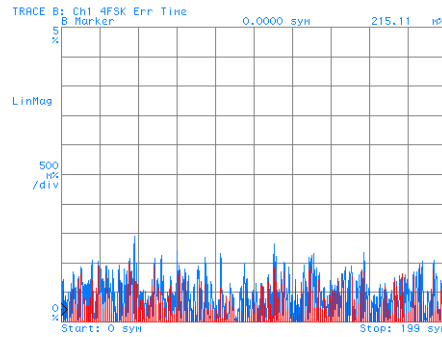
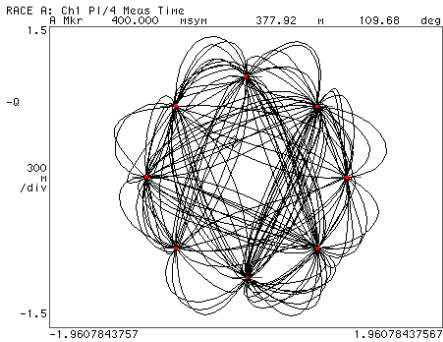

FSK error (typ.) 1.5 % (0 dBm)

GSM $(GMSK, 270.833$ kS/s, 935 MHz)
 EVM (typ.) 0.3 % (0 dBm)

GSM $(GMSK, 270.833$ kS/s, 1.932 GHz)
 EVM (typ.) 0.6 % (0 dBm)

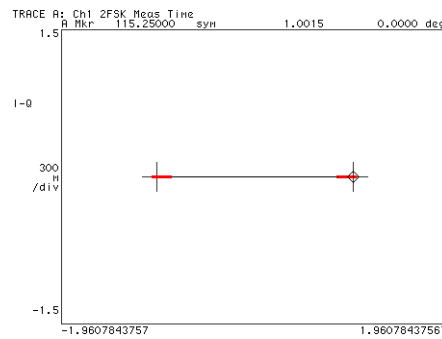
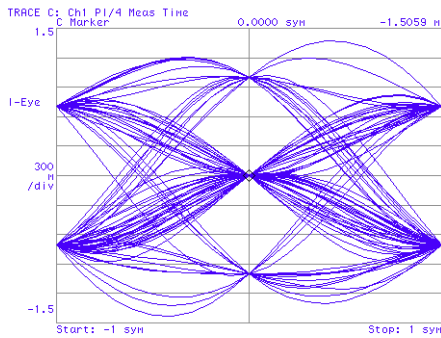

APCO-25 $(FSK4-C4FM, 4.8$ kS/s, 850 MHz)
 FSK error (typ.) 0.46 % (0 dBm)

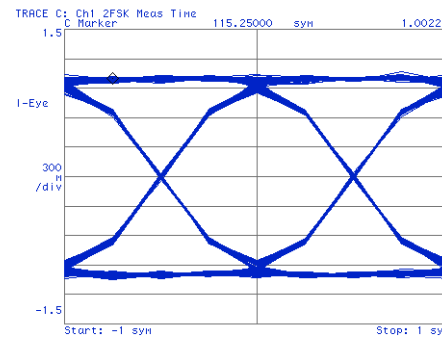
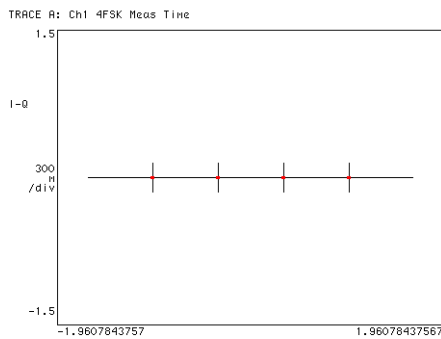

DECT (FSK2, 1.152 Mbps, 1.925 GHz)

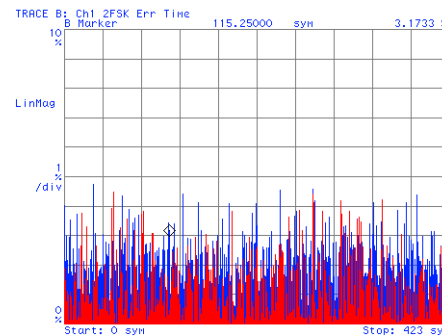
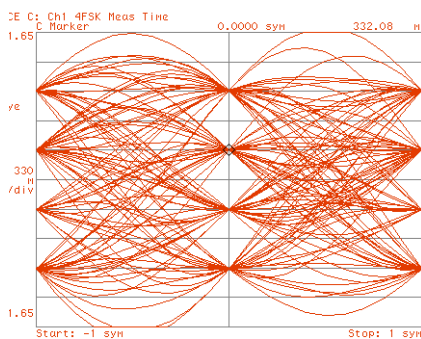

SG390 Series Specifications (Vector)

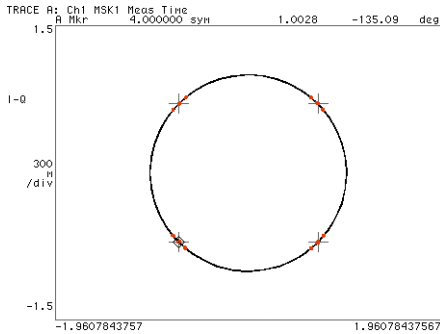

GSM constellation (935 MHz carrier)

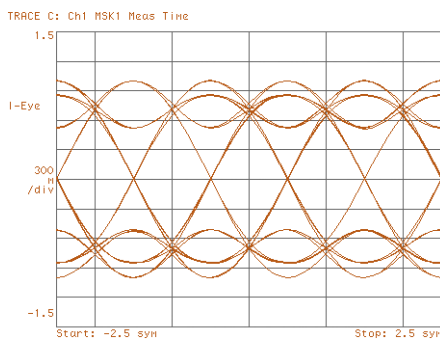

GSM I-Eye diagram (935 MHz carrier)

- GSM-EDGE** (3π/8 8PSK, 270.833 kS/s, 935 MHz) EVM (typ.) 0.3 % (0 dBm)
- GSM-EDGE** (3π/8 8PSK, 270.833 kS/s, 1.932 GHz) EVM (typ.) 0.5 % (0 dBm)
- W-CDMA** (QPSK, 3.840 Mcps, 1.850 GHz) EVM (typ.) 1.7 % (0 dBm)

RMS EVM: Max 0.30 % Avg 0.30 %
 Pk EVM: Max 0.74 % Avg 0.74 %
 95%tile EVM: 0.54 %
 Mag Error: 0.18 %
 Phas Error: 0.34 °
 Freq Error: -7.39 Hz
 I/Q Offset: -39.98 dB
 Amplitude Droop (142 syms): -0.01 dB
 TSC: 0
 AMPM Offset: ---
 T0 Offset: 278.855 μs

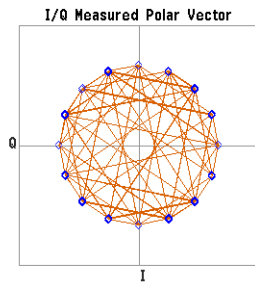

GSM-EDGE constellation (935 MHz carrier)

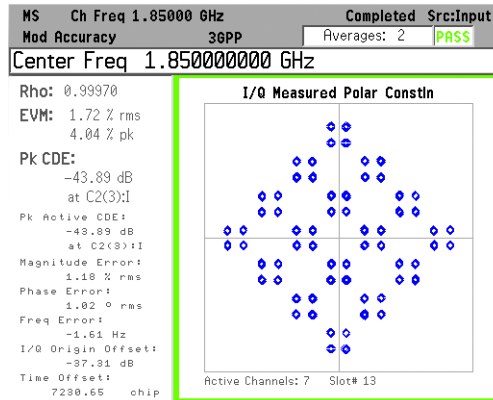

W-CDMA constellation (1.85 GHz)

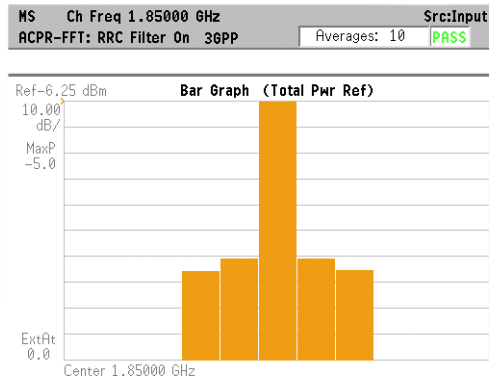

W-CDMA ACPR

- QAM256** (6 MS/s, 2.450 GHz) EVM (typ.) 1.1 % (0 dBm)

QAM32

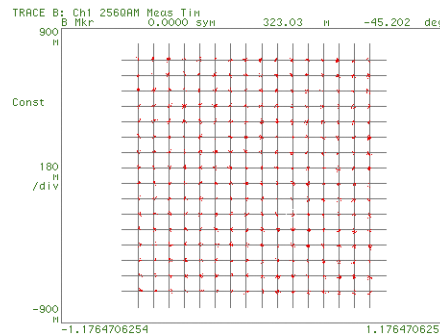

QAM256 constellation (2.45 GHz carrier)

TRACE D: Ch1 256QAM Syms/Err		0.0000 syn		157.00	
D Marker					
EVM	= 1.0329	%rms	2.6403	% pk at syn	5
Mag Err	= 731.63	m%rms	2.4356	% pk at syn	1631
Phase Err	= 1.1274	deg	-0.8221	deg pk at syn	548
Freq Err	= -180.12	MHz			
I/Q Offset	= -42.161	dB	SNR (MER)	= 35.479	dB
Quadr Skew	= 931.56	hdeg	Gain (dB)	= 0.047	dB

(6 MS/s, 5.800 GHz)
 EVM (typ.) 2.5 % (0 dBm)

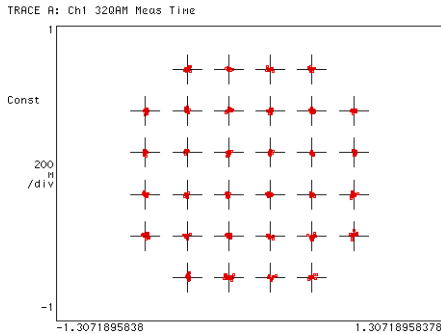

*QAM32 constellation
 (5.8 GHz carrier)*

TRACE D: Ch1 320AM Syms/Errs

EVM	= 1.5680	%rms	4.3403	% pk at sym	290
Mag Err	= 1.0095	%rms	2.8451	% pk at sym	373
Phase Err	= 1.4970	deg	-6.3927	deg pk at sym	40
Freq Err	= 688.38	MHz			
IQ Offset	= -37.279	dB	SNR (NER) = 32.119	dB	

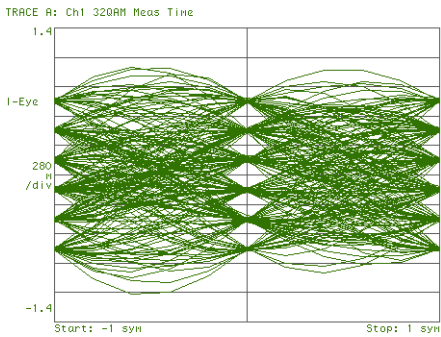

*QAM32 I-Eye diagram
 (5.8 GHz carrier)*

ATSC-DTV
 EVM (typ.) 2.2 % (0 dBm) (8 VSB, 10.762 MS/s, 695 MHz)

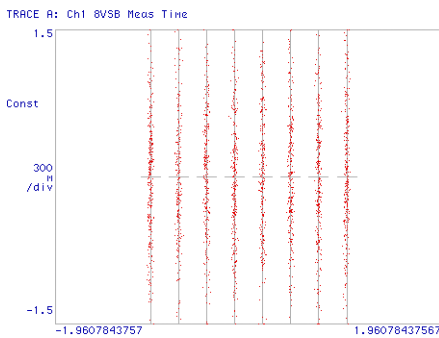

*ATSC-DTV (8VSB) constellation
 (695 MHz carrier)*

По вопросам продаж и поддержки обращайтесь:

Алматы (7273)495-231	Казань (843)206-01-48	Новокузнецк (3843)20-46-81	Смоленск (4812)29-41-54
Архангельск (8182)63-90-72	Калининград (4012)72-03-81	Новосибирск (383)227-86-73	Сочи (862)225-72-31
Астрахань (8512)99-46-04	Калуга (4842)92-23-67	Омск (3812)21-46-40	Ставрополь (8652)20-65-13
Барнаул (3852)73-04-60	Кемерово (3842)65-04-62	Орел (4862)44-53-42	Сургут (3462)77-98-35
Белгород (4722)40-23-64	Киров (8332)68-02-04	Оренбург (3532)37-68-04	Тверь (4822)63-31-35
Брянск (4832)59-03-52	Краснодар (861)203-40-90	Пенза (8412)22-31-16	Томск (3822)98-41-53
Владивосток (423)249-28-31	Красноярск (391)204-63-61	Пермь (342)205-81-47	Тула (4872)74-02-29
Волгоград (844)278-03-48	Курск (4712)77-13-04	Ростов-на-Дону (863)308-18-15	Тюмень (3452)66-21-18
Вологда (8172)26-41-59	Липецк (4742)52-20-81	Рязань (4912)46-61-64	Ульяновск (8422)24-23-59
Воронеж (473)204-51-73	Магнитогорск (3519)55-03-13	Самара (846)206-03-16	Уфа (347)229-48-12
Екатеринбург (343)384-55-89	Москва (495)268-04-70	Санкт-Петербург (812)309-46-40	Хабаровск (4212)92-98-04
Иваново (4932)77-34-06	Мурманск (8152)59-64-93	Саратов (845)249-38-78	Челябинск (351)202-03-61
Ижевск (3412)26-03-58	Набережные Челны (8552)20-53-41	Севастополь (8692)22-31-93	Череповец (8202)49-02-64
Иркутск (395)279-98-46	Нижний Новгород (831)429-08-12	Симферополь (3652)67-13-56	Ярославль (4852)69-52-93
Россия (495)268-04-70	Киргизия (996)312-96-26-47	Казахстан (7172)727-132	

rsy@nt-rt.ru || <https://srs.nt-rt.ru/>