

QMS100, QMS200, QMS300

Технические характеристики

По вопросам продаж и поддержки обращайтесь:

Алматы (7273)495-231	Казань (843)206-01-48	Новокузнецк (3843)20-46-81	Смоленск (4812)29-41-54
Архангельск (8182)63-90-72	Калининград (4012)72-03-81	Новосибирск (383)227-86-73	Сочи (862)225-72-31
Астрахань (8512)99-46-04	Калуга (4842)92-23-67	Омск (3812)21-46-40	Ставрополь (8652)20-65-13
Барнаул (3852)73-04-60	Кемерово (3842)65-04-62	Орел (4862)44-53-42	Сургут (3462)77-98-35
Белгород (4722)40-23-64	Киров (8332)68-02-04	Оренбург (3532)37-68-04	Тверь (4822)63-31-35
Брянск (4832)59-03-52	Краснодар (861)203-40-90	Пенза (8412)22-31-16	Томск (3822)98-41-53
Владивосток (423)249-28-31	Красноярск (391)204-63-61	Пермь (342)205-81-47	Тула (4872)74-02-29
Волгоград (844)278-03-48	Курск (4712)77-13-04	Ростов-на-Дону (863)308-18-15	Тюмень (3452)66-21-18
Вологда (8172)26-41-59	Липецк (4742)52-20-81	Рязань (4912)46-61-64	Ульяновск (8422)24-23-59
Воронеж (473)204-51-73	Магнитогорск (3519)55-03-13	Самара (846)206-03-16	Уфа (347)229-48-12
Екатеринбург (343)384-55-89	Москва (495)268-04-70	Санкт-Петербург (812)309-46-40	Хабаровск (4212)92-98-04
Иваново (4932)77-34-06	Мурманск (8152)59-64-93	Саратов (845)249-38-78	Челябинск (351)202-03-61
Ижевск (3412)26-03-58	Набережные Челны (8552)20-53-41	Севастополь (8692)22-31-93	Череповец (8202)49-02-64
Иркутск (395)279-98-46	Нижний Новгород (831)429-08-12	Симферополь (3652)67-13-56	Ярославль (4852)69-52-93
Россия (495)268-04-70	Киргизия (996)312-96-26-47	Казахстан (7172)727-132	

Atmospheric Sampling Systems

QMS systems — 100 amu, 200 amu, and 300 amu



QMS Series Atmospheric Sampling Systems

- 100, 200 or 300 amu systems
- Pressures from 10 mbar to 1 bar
- Better than 1 amu resolution
- <0.5 second response time
- Compact, transportable design
- 6 decades of dynamic range
- RGA Windows software
- RS-232 computer interface

QMS series gas analyzers offer an efficient, cost-effective solution for a wide range of applications. These mass spectrometers simplify the task of on-line process monitoring, analysis of gas species, leak detection, and troubleshooting.

On-Line Monitoring

The QMS system can continuously sample gas at low flow rates of several milliliters per minute. The inlet can be equipped to sample at pressures from 1 bar to 10 mbar. Data is acquired continuously, as opposed to batch sampling which is employed by gas chromatographs. The QMS system has a fast response time of less than 0.5 seconds. Complete spectra can be recorded in seconds, and individual masses can be measured at rates up to 25 points per second.

Compact, User-Friendly Design

An advanced quadrupole mass spectrometer design, coupled with state-of-the-art pumping technology, allows the entire system to be integrated in a small, transportable package. The sampling inlet valves and pumps can be controlled from the front panel. Operation is easy and does not require a detailed understanding of the quadrupole or the pressure reducing inlet. Since the pumps contain no oil or other liquids, gravity has no effect on them which allows the unit to function either standing upright or laid on its side. Capillaries are used as sampling probes and are available in a variety of materials and sizes for different applications.

Principle of Operation

The QMS uses a two-stage, pressure-reducing inlet to sample gases at high pressure. This allows the use of a residual gas analyzer (which operates at high vacuum) as the detector. Different capillaries permit the system to sample at higher or lower pressures. A large flow is drawn through the capillary which drops the pressure three decades. A hybrid

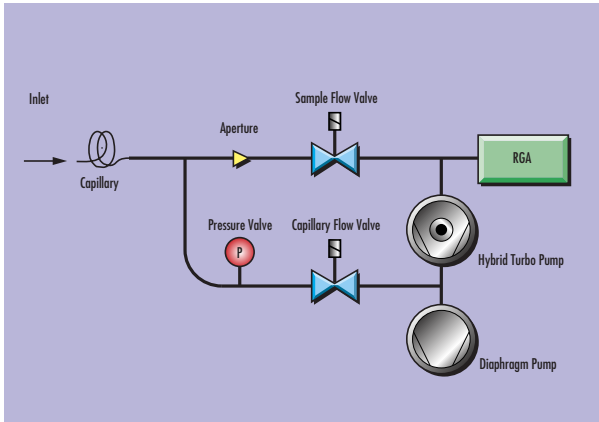

QMS schematic

turbomolecular/drag pump draws a small amount of gas through an aperture, which reduces the pressure to about 10^{-6} Torr, while most of the flow is bypassed directly to a diaphragm pump. Solenoid valves control the gas flow. The entire system is controlled by a microprocessor which ensures correct operation of the pumps and valves. The software manages the spectrometer and acquires data in a choice of six different modes. An optional rear-panel, high-vacuum 2.75" Conflat® port provides direct access to the RGA.

Bypass Flow Configuration

The bypass flow stream and the sample flow stream are recombined at the diaphragm pump, which makes it possible to use only one backing pump. This contributes to the system's small size. The bypass flow configuration is also critical to the fast response time of the QMS. Single-stage pressure reduction with leak valves would lead to extremely small flow rates and unreasonably long sample times. The bypass flow, on the other hand, gives a response time of less than 0.5 seconds from the tip of the capillary to the RGA chamber.

Windows Software

The QMS systems are supported with a Windows software package that runs on PCs. The intuitive graphical user interface allows measurements to be made quickly and easily. Data is captured and displayed in real time or scheduled for acquisition at specified time intervals. Features include analog and histogram scan modes, pressure vs. time plots, leak detection, annunciator mode, gas library, audio and visual

alarms, and comprehensive on-line help. Probe parameters can also be controlled and monitored through a high-level ASCII command set which allows easy integration into user control programs. A standard RS-232 interface is used as the data link to the host computer. A LabVIEW driver is also available on the SRS website.

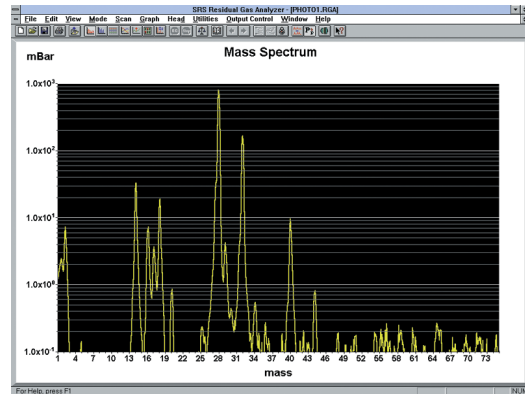

RGA Windows software— Analog mode

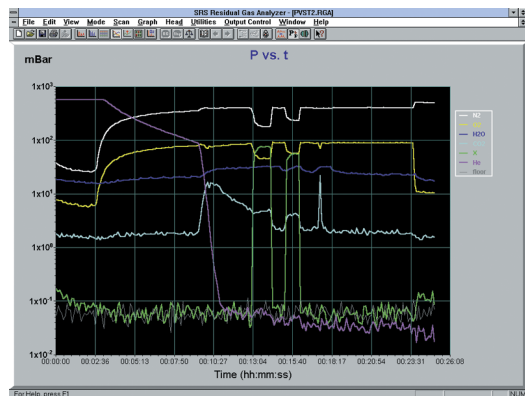

RGA Windows software— P vs. T mode

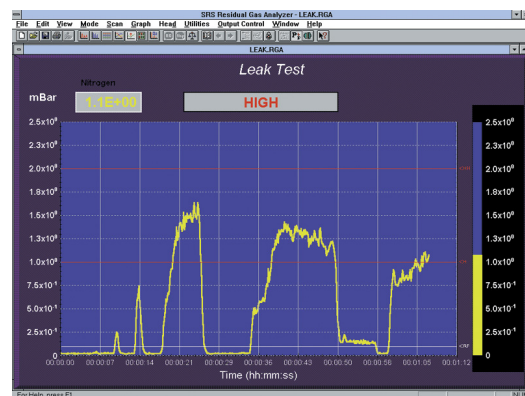

RGA Windows software— Leak Detection mode

QMS Specifications

Inlet

Type	Capillary (available in stainless steel and PEEK)
Flow rate	1 to 10 milliliter per minute at atmospheric pressure
Pressure	10 mbar to greater than 1 bar (depending on capillary)

Mass Spectrometer

Type	Quadrupole
Detectors	Faraday cup & electron multiplier
Range	100, 200 or 300 atomic mass units
Resolution	Better than 0.5 amu at 10% of peak height
Detection limit	<1 ppm
Operating pressure	5×10^{-6} mbar

Connections

Inlet	1/4" Ultra-Torr® fitting
Computer interface	RS-232C, 28.8 kbaud, DB9 connector (25 ft. RS-232 cable included)
Software	RGA Windows application

System

High-vacuum pump	Hybrid turbo-molecular
Diaphragm pump	Advanced low pressure

Materials

Construction	SS304 and SS316
Insulators	Alumina, ceramic

Seals

Viton®, buna-N, and nitrile butyl rubber
Aluminum, Tygon®

Miscellaneous

General

Start-up time	5 minutes from full stop
Max. ambient operating temp.	35 °C
Power requirement	110 VAC/60 Hz or 220 VAC/50 Hz (not field selectable)
Dimensions	7.06" × 17.25" × 24.80" (WHD)
Weight	75 lbs.
Warranty	One year parts and labor on defects in materials and workmanship. Pump seals and diaphragm warranted for 90 days.

Ordering Information

QMS100	100 amu sampling system
QMS200	200 amu sampling system
QMS300	300 amu sampling system
Option 01	High-vacuum rear port
O100BV	Bypass valve assembly w/ orifice
O100REA	Ethernet adapter
PPM100	Optional stand-alone monitor

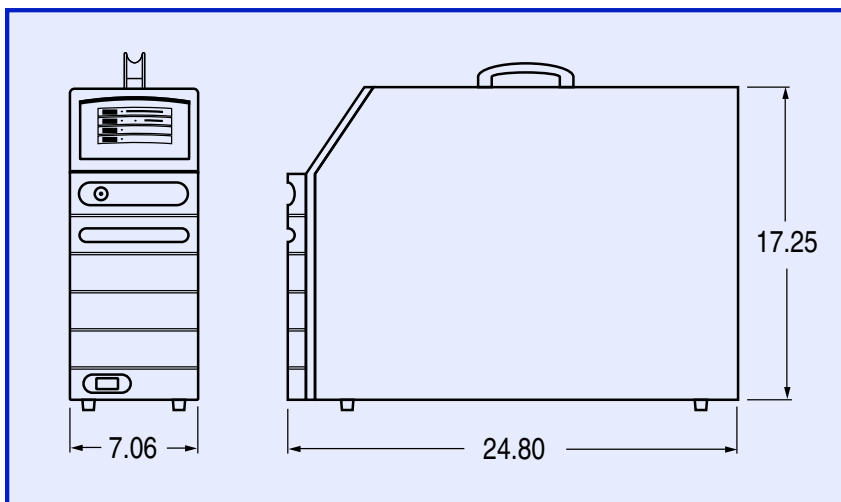

QMS100 rear panel (w/ Option 01)

По вопросам продаж и поддержки обращайтесь:

Алматы (7273)495-231	Казань (843)206-01-48	Новокузнецк (3843)20-46-81	Смоленск (4812)29-41-54
Архангельск (8182)63-90-72	Калининград (4012)72-03-81	Новосибирск (383)227-86-73	Сочи (862)225-72-31
Астрахань (8512)99-46-04	Калуга (4842)92-23-67	Омск (3812)21-46-40	Ставрополь (8652)20-65-13
Барнаул (3852)73-04-60	Кемерово (3842)65-04-62	Орел (4862)44-53-42	Сургут (3462)77-98-35
Белгород (4722)40-23-64	Киров (8332)68-02-04	Оренбург (3532)37-68-04	Тверь (4822)63-31-35
Брянск (4832)59-03-52	Краснодар (861)203-40-90	Пенза (8412)22-31-16	Томск (3822)98-41-53
Владивосток (423)249-28-31	Красноярск (391)204-63-61	Пермь (342)205-81-47	Тула (4872)74-02-29
Волгоград (844)278-03-48	Курск (4712)77-13-04	Ростов-на-Дону (863)308-18-15	Тюмень (3452)66-21-18
Вологда (8172)26-41-59	Липецк (4742)52-20-81	Рязань (4912)46-61-64	Ульяновск (8422)24-23-59
Воронеж (473)204-51-73	Магнитогорск (3519)55-03-13	Самара (846)206-03-16	Уфа (347)229-48-12
Екатеринбург (343)384-55-89	Москва (495)268-04-70	Санкт-Петербург (812)309-46-40	Хабаровск (4212)92-98-04
Иваново (4932)77-34-06	Мурманск (8152)59-64-93	Саратов (845)249-38-78	Челябинск (351)202-03-61
Ижевск (3412)26-03-58	Набережные Челны (8552)20-53-41	Севастополь (8692)22-31-93	Череповец (8202)49-02-64
Иркутск (395)279-98-46	Нижний Новгород (831)429-08-12	Симферополь (3652)67-13-56	Ярославль (4852)69-52-93
Россия (495)268-04-70	Киргизия (996)312-96-26-47	Казахстан (7172)727-132	

rsy@nt-rt.ru || <https://srs.nt-rt.ru/>